

ATEX CAMERA ENCLOSURES : XD 120 H WIN SERIES

CHARACTERISTICS :

The XD 120H series enclosures with glass are designed to accommodate various electronic instruments or vision camera type instruments. The case is equipped with a standard glass for all camera surveillance applications, excluding thermal camera. These boxes can be installed in zones 1,2,21,22 with the assembly of cable glands necessary to obtain an Exd protection with an IP of 54 to 68.

CERTIFICATION :

ATEX FTZU 08 ATEX 0181U
IECEX FTZU 11.0012U

MARKING :

II2 GD Ex db IIC Gb – II2 D Ex tb IIIC Db

APPLICATIONS :

- Oil and Gaz Refinery
- Petrochemical chemistry
- Onshore plants
- Offshore plants
- Oil and Gas Transportation
- Fuel depot
- Extreme temperature

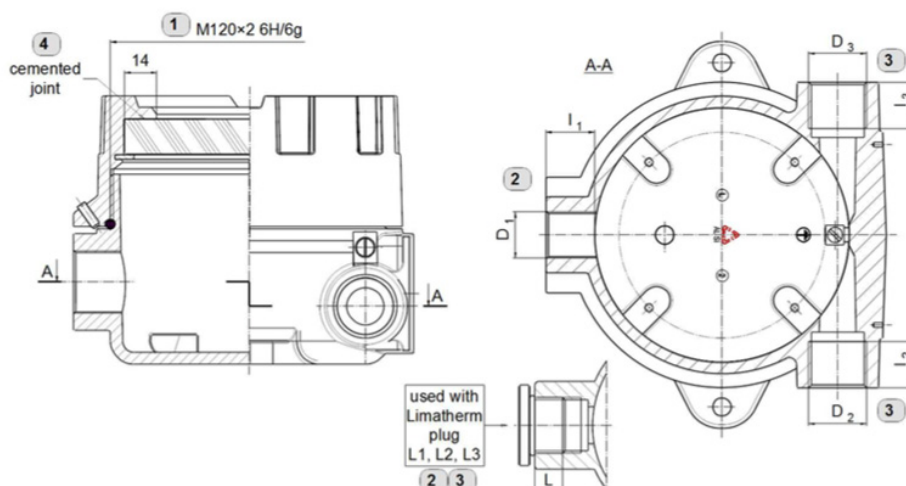

DIMENSIONS :

Lp.	Connection type	Requirements of 60079-1
1	M120x2 6H/6g	threads engaged ≥ 5 depth of engagement ≥ 8 mm
2	D ₁ proces opening	M20x1.5 6H M24x1.5 6H M25x1.5 6H
		fit of thread
		threads engaged ≥ 5
		depth of engagement ≥ 8 mm
		M27x2 6H
		fit of thread
threads engaged ≥ 5		
depth of engagement ≥ 8 mm		
3	D ₂ , D ₃ conduit openings	M20x1.5 6H M24x1.5 6H M25x1.5 6H
		fit of thread
		threads engaged ≥ 5
		depth of engagement ≥ 8 mm
½NPTmod ¾NPTmod	threads provided on each part ≥ 5	
	threads engaged	
4	Cemented joint	min. length of joint 10mm

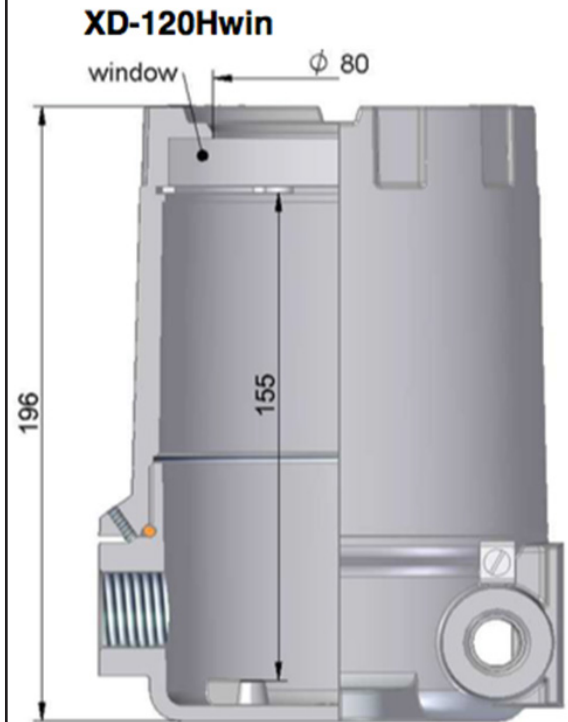

ATTENTION :

IP65 minimum protection is required for instruments designed for dusty areas.
(In addition to zone 22, non-conductive dust for which a minimum protection IP5 4 is required)